

OPTIONEEL:

- Roeras zonder flensverbinding (type A)
- Roeras met vierkant voor noodbesturing
- Lieverarm (los meegeleverd)

OPTIONAL:

- Rudder shaft without flanges (type A)
- Rudder shaft with square shaft end for emergency steering
- Tillerarm (separate delivered)

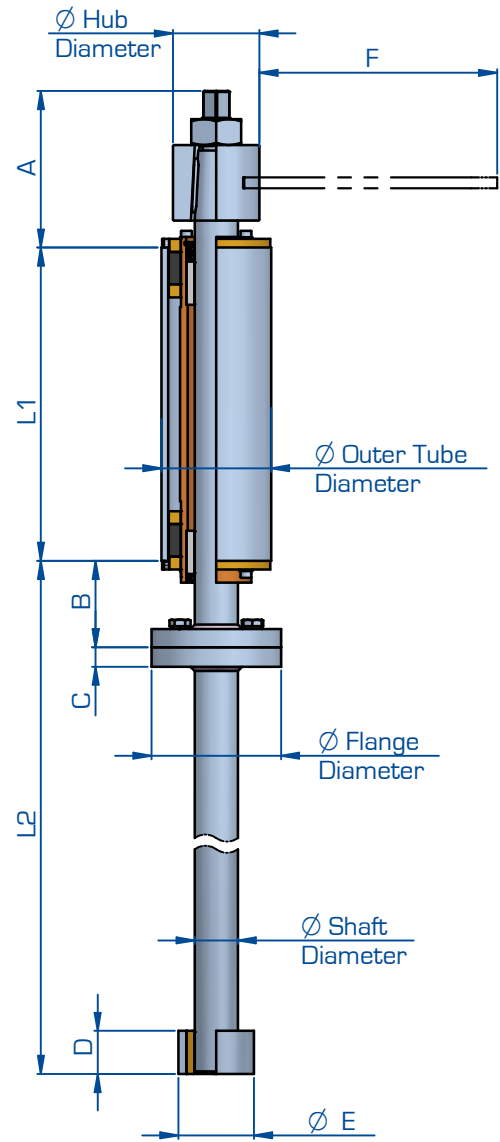

BNF OptiProp - Rudder System (self-lubricating)

Shaft Diameter	Outer Tube Dimensions	Hub Diameter	Flange Diameter	A	B	C	D	E	F
Ø35	Ø101,6 x 6,3	Ø60	Ø120	103	75	20	35	60,3	210
Ø40	Ø101,6 x 6,3			145	80	20	40	70	220
Ø45	Ø127 x 7,1	Ø80	Ø150	149	85	20	45	76,1	220
Ø50	Ø127 x 7,1			151	90	20	50	76,1	300
Ø60	Ø146 x 7,1	Ø90		151	100	20	60	88,9	300

De maten L1 en L2 volgens opgave klant

Dimensions L1 and L2 according indication customer

THIS DRAWING IS PROPERTY OF BLOKLAND NON-FERRO BV
IT IS NOT ALLOWED TO COPY OR LENT WITHOUT
PERMISSION OF BLOKLAND NON-FERRO

UNIT OF MEASURE : mm		FORM AND POS. TOL. ACC. TO NEN-ISO 1101		SURFACE ROUGHNESS ACC. TO NEN 3634	
PROJECTION		DRAWN : J.H. van Dalen		DATE : 14-12-2011	
		SCALE : n.v.t		CHECK : -	
LINEAR AND CIRCULAR TOLERANCES UNLESS STATED DIFFERENTLY				BNF OptiProp - Rudder System (Self-Lubricating)	
NOMINAL DIMENSIONS					
OVER	-	6	30	100	300
UP TO	6	30	100	300	1000
TOL.	±0,1	±0,2	±0,3	±0,5	±0,8
ANGULAR TOL. UNLESS STATED DIFFERENTLY : ± 30'				SERIAL NUMBER: —	
Lelystraat 106 3364 AJ Sliedrecht, Holland		Tel: +31 (0) 184 413 789 Fax: +31 (0) 184 419 379		E-mail: info@bloklandnonferro.nl Website: www.bloklandnonferro.nl	
REV.		DATE		DESCRIPTION	
				DESCRIPTION: A4 DRAWING NUMBER: 45-000000-001 REVISION:	
		SHEET : 1 OF 1		WEIGHT:kg	

Blokland
non-ferro bv

